

Here is an Active Inference Generative Model, expressed as a Bayesian Graph

A = Emission matrix of States
 B = Transition matrix of States
 C = Preferences
 D = Prior on State estimates
 E = Affordances
 G = Expected Free Energy
 π = Policy
 o_t = Observations through time
 s_t = State estimates through time

Let's consider this model in terms of what GPT does right now –

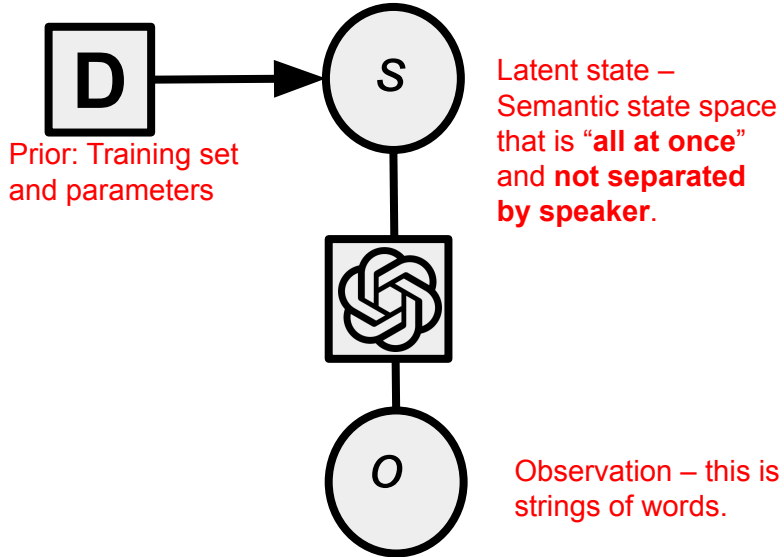

First let's add in temporal dynamics, using the "Perceptual Inference" part of the full Active Inference model (there is no Action Selection in this model, just Hidden States changing through time & emitting Observations at each time)

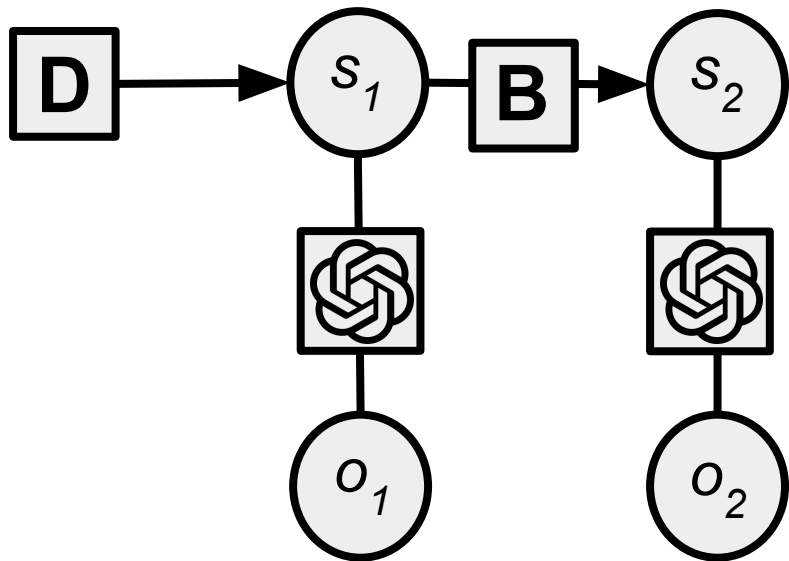

B is the transition matrix – describes how Hidden (semantic) Spaces evolve through time. This leads to the question of how time is treated, which we have discussed a few approaches for!

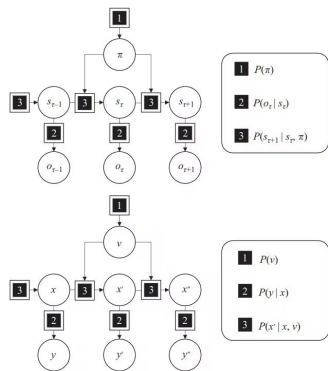

Here is the Figure 4.3 from Parr et al. 2022 Textbook – Top is Discrete time, Bottom is Continuous. We can do anything we want with embeddings, wavelets, Generalized Coordinates, etc.

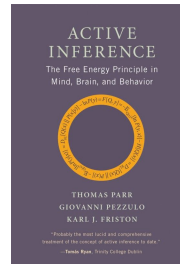

Now that the model has a temporal aspect, we can see a possible way to address the second issue, that all speakers are admixed (and hence cannot have differential weighting or attention). Here is one possibility – using the renormalization group approach towards modeling collective behavior from Friston et al. 2023

The multiple meme accounts (aliases, or subideas) one person operates
 The group of people
 The set of groups
 The Biophysical Eco-Niche
Black line is Thickness of Attention

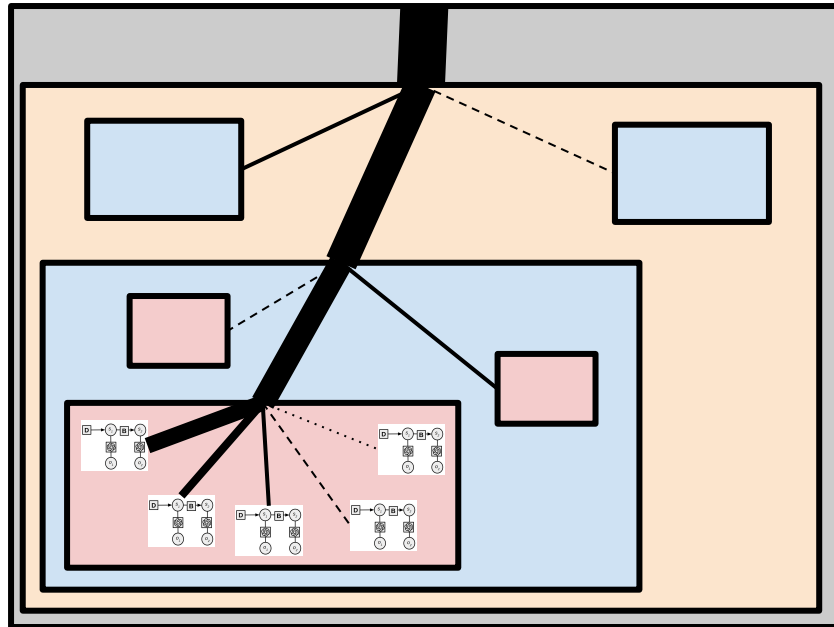

It is a portfolio (regime) of nested attentions at all levels.
 Here, one person has 5 ideas, the left one (their right!) is the most attended to
 That person is most regarded in their group, which is the most regarded group of groups.
 Overall though, the biophysical/energetic reality of this whole mobile only has a single root (at least in this map).

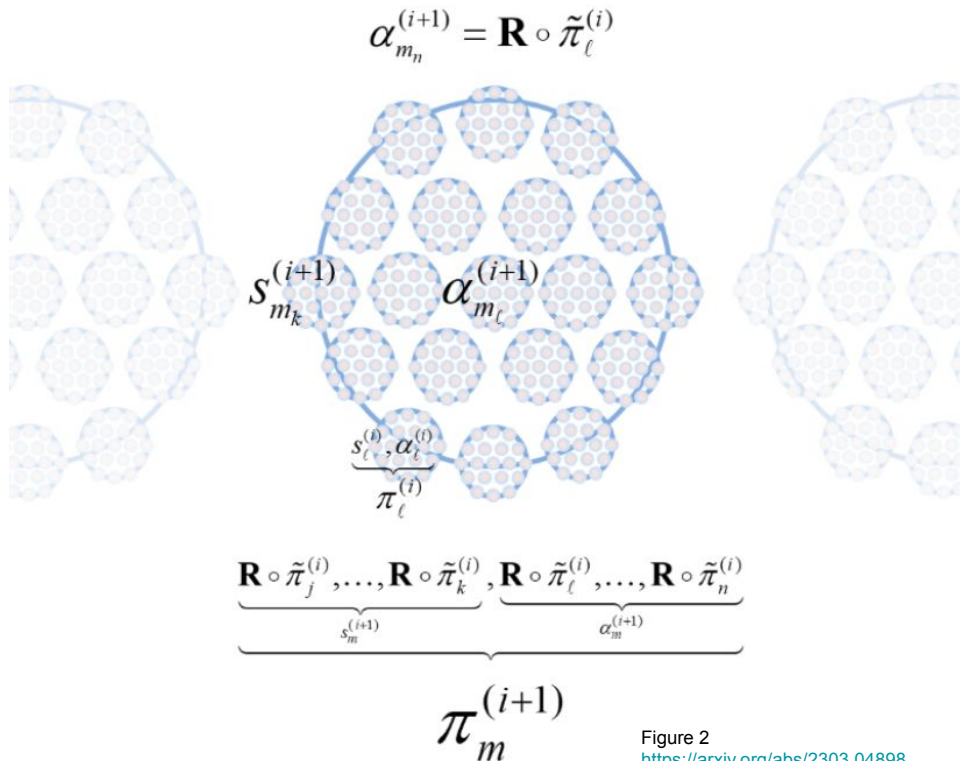

Figure 2
<https://arxiv.org/abs/2303.04898>
 Friston, Friedman, et al. 2023

To-Do

- **Adding in examples of Visualizations and Dashboard** (*“you scan a context and some sort of model can give a summary with charts and visualizations”*)
- **Specification of this model in GNN** so that we can move it towards implementation.
- **Adding in Action component** (e.g. *“Given my current estimates of Hidden States, and Preference over Observations, what Actions can/should I take?”*)
-
- .
- .
- .

